



CONCRETE BLOCK (CB)

Production and Construction Guide



Government of India
Department of Science & Technology
Ministry of Science & Technology



CONCRETE BLOCK (CB) Production and Construction Guide

ISBN	:	978-81-87395-78-2 (4)
Published by	:	Development Alternatives B-32, Tara Crescent, Qutub Institutional Area New Delhi 110016, India Tel: +91-11-2654-4100, 2654-4200 Fax: +91-11-2685-1158 Email: mail@devalt.org, Website: www.devalt.org
Cover Photo Credit	:	Development Alternatives
Author(s)	:	Zeenat Niazi, Pankaj Khanna, Suhani Gupta, Rashi Sirohi
Layout	:	Binu K George

Disclaimer

This document is an outcome of a project titled, "Delivery of Eco-Friendly Multi-Hazard Resistant Construction Technologies and Habitat Solutions in Mountain States, Focus: Uttarakhand" funded by "The Department of Science and Technology (DST), New Delhi" for the economic development, social empowerment and environment management of our society. This document is intended for use by policy-makers, academia, government, non-government organisations and general public for guidance on matters of interest only. The decision and responsibility to use the information contained in this document lies solely with the reader. The author(s) and the publisher(s) are not liable for any consequences as a result of use or application of this document. Content may be used/quoted with due acknowledgement to Development Alternatives.



This work is licensed under the Creative Commons Attribution-NonCommercial-ShareAlike 4.0 International License.

Suggested Citation

Niazi, Z., Khanna, P., Gupta, S., and Sirohi, R. (2020) *Concrete Block (CB) - Production and Construction Guide*. New Delhi: Development Alternatives.

TABLE OF CONTENTS

1. Background	5
2. Technology Profile	7
2.1 Concrete Block Technology	8
2.2 Technical specifications	8
2.3 Applicability	9
2.4 Advantages	9
3. Production Infrastructure	10
3.1 Production equipment	11
3.2 Maintenance	12
3.3 Production unit	12
3.4 Material and manpower requirement for production	13
4. Production Process	15
4.1 Preparation of CB mix	16
4.2 Block production	18
5. Construction Process	21
5.1 Design	22
5.2 CB Masonry	25
6. Communication Material	28
6.1 Technology Production Poster – A3 size	29
6.2 Technology Production Poster – A2 size	33

INTRODUCTION

This manual has been prepared as part of a project on '*Delivery Model for Eco-friendly Multi Hazard Resistant Construction Technologies and Habitat Solutions in Mountain States*', which has been implemented in Uttarkashi (Uttarakhand) under the TIME LEARN (Technology Innovation in Mountain Ecosystem Livelihood Enhancement through Action Research and Networking) programme of the Department of Science and Technology. The project envisage to introduce new system of construction in the region which are resource and energy efficient, can be produced locally in a decentralized production setup, cost effective and easy to adapt. Considering all the above factors, **Concrete Blocks (CB)** was proposed in the region. The technology was produced locally at an enterprise unit setup developed under the project. The local artisans and contractors were trained in the technology specifications, production and its implementation through demonstration buildings at the project area.

This manual has been prepared as a guide for the use of building artisans, entrepreneurs and government officials for production and implementation of Stabilized Compressed Earth Block wall masonry in mountain regions. The manual is comprised of five sections – First, **Background** which covers a brief about the CB technology and its application in the context of Uttarakhand region, Second, **Technology Profile** covers all the design and technical details of the technology. Third, **Production of Blocks** covers all details of technology production along with the specification of production unit. Fourth, **CB Applications** covers the construction details and specification of the technology and Lastly, **Communication Products** shows all the posters developed for the community trainings.

Background

Construction practices in the mountain regions have been changing rapidly, mainly under the influence of cement-based practices. These are perceived as stronger, particularly to resist earthquakes and the penetration of cement from plain regions have accelerated a change among locals to shift from traditional construction practices to new/modern building materials. Although, traditionally used building materials have not completely disappeared and new materials have been introduced, hence most often the blend of two are observed in the region. One of the common practice for wall masonry observed in Uttarkashi region is the use of concrete blocks- a large sized masonry unit made by compacting concrete in a mould. It is produced by locals, house-builders by using simple moulds and has been adopted as a modern construction material in addition to red burnt clay bricks. – considered to provide more structural stability since made of concrete. Although it is an appropriate material for localized production, there is no awareness of its basic requirements for quality- namely the correct mix and adequate compaction. This has resulted in very poor quality blocks being made and used in construction. Since, it is comparatively new material in the region, there is no awareness regarding the correct masonry practice of concrete blocks – most often it was found to be used as a filler in a stone masonry wall or with direct load of RCC slab on it.



The use of concrete blocks as a filler in stone wall masonry at Thandi village, Uttarkashi



The concrete block masonry with direct load of RCC slab on it at Kamad village, Uttarkashi

Concrete Block (CB) technology was identified as a potential building technology to be proposed in the region with technical improvements which can be easily adapted in the region. Concrete blocks produced with standardized production methods using standard machines and moulds and vibrating plate to attain compaction for higher strength. Also, hollow concrete block were introduced to add reinforcement in concrete block masonry to attain high structural stability.

Technology Profile

Concrete blocks (CB) are precast masonry units which are cuboid in shape, in solid and as well as in hollow form and made with plain cement concrete of a lean mix-proportion. In addition to the basic components, the concrete for making blocks may also contain additives like admixtures to increase compressive strength, or improve workability. They have also been produced with improved textures for better durability and appearance using stone chips or glazed surfaces.



Residential building using concrete block in Srinagar, Uttarakhand

Technical specifications

Raw materials	Cement	Ordinary Portland Cement Grade 33 (IS 269) or 43 (IS 8112), or Portland Pozzalana cement grade confirming to IS 1489 Part I
	Coarse aggregate	Different sizes for a well-graded mix. This can include sizes from 6mm, 10mm, 20mm and even 40mm depending on availability of raw material and the performance requirements of block.
	Fine Sand	Sand should be washed and should not contain dirt Stone dust may also be used confirming to Grading Zone II as per IS 383:1970
	Fly Ash	Fly ash confirming to IS 3812 may be used for part replacement of fine aggregate upto a limit of 20%
	Design mix	Lean concrete mix of 1:3:8 or 1:5:8
Cement concrete block Open and closed cavity Hollow Blocks (Load Bearing), and Solid Blocks(Load bearing)	Size	Sizes can be customized as per mould, some common sizes are – Length – 16 inch, 12 inch, 8 inch Width – 3 inch, 4 inch, 6 inch, 8 inch Height – 5 inch, 6 inch, 8 inch
	Compressive strength(hollow-open and closed cavity)	Broadly classified into Class 5.5, 7, 8.5, 10, 12.5, 15 – corresponding to Average Compressive Strength not less than 55, 70, 85, 100, 125,150 kg/cm ²

	Compressive strength(solid load bearing)	Broadly classified into Class 4 and 5 corresponding to Average Compressive Strength not less than 40 and 50 kg/cm ²
	Water absorption	Not more than 6% of the mass after immersion in cold water for 24 hours
Mortar for masonry	Design Mix	Cement Sand mortar 1:6

Applicability

Concrete has a wide application in construction across various parts of a building – from foundation to columns to roof, because it can be formed into various shapes. One of such use is Concrete blocks which have been in use in India for nearly four decades and are commonly found in all parts of the country- both rural and urban. They also owe their popularity to the fact that speed of construction is enhanced since the blocks bigger than burnt bricks.

The technology can be widely adopted in place of burnt clay bricks for both load bearing and non-load bearing construction. The production of blocks is economically feasible wherever cement and aggregates are easily available. It is also a viable option for micro-enterprise based local availability of masonry materials in a housing project.

Advantages of CB

Cost	<ul style="list-style-type: none"> • Cost reduction of 10-15% in brick and mortar cost can be achieved with economical availability of concrete blocks. Bigger blocks save mortar consumption. • Lesser wastage of blocks due to better quality and more uniform size. • With better quality blocks having clean finish and edges, there is option of exposed masonry and also of lean plaster which can save cost of plastering and painting.
Environment	<ul style="list-style-type: none"> • Consumes lesser energy in production than conventional burnt clay bricks
Aesthetics	<ul style="list-style-type: none"> • With better quality blocks having clean finish and edges, there is option of exposed masonry • Uniform size and shape with tolerance of 3-5 mm makes it ideal for neat and clean masonry.
Employment	<ul style="list-style-type: none"> • Generates employment in SME sector along with good opportunity in retail selling. • It is also a viable option for micro-enterprise based local availability of masonry materials in a housing project.
Water Protection	<ul style="list-style-type: none"> • Outdoor concrete blocks have very low water absorption • Moreover, concrete blocks are breathable, don't freeze and are easily cleaned.

Production Infrastructure

Production Equipment

Concrete Blocks can be produced locally by using small vibrating table and basic tools and accessories for a uniform mix quality. In addition to regular blocks, special blocks with a single cavity can be produced for incorporating single bar vertical reinforcement wall using a well graded cement concrete mix. Development Alternatives designed TARA Balram Manual - Concrete Block press to suit typical conditions in rural areas in terms of skill level of manpower and accessibility of construction sites. The machine and its production accessories are fabricated by TARA Machines and Tech Services Pvt. Ltd. (TMTS)

Equipment	Specifications	Quantity (Nos.)
TARA Eco Concrete - ½ Bag concrete mixer	Concrete mixer small fitted with 1hp motor	1
TARA Eco Concrete - Vibrating table small type	Vibrating table 4 feet x 4 feet, fitted with 3 phase vibratory motor.	1
Metallic Mould	MS fabricated moulds for Solid Concrete Block size (LXBXH): 300 x 200 x 150 mm for external load bearing wall.	4
Metallic Mould	MS fabricated moulds for Solid Concrete Block size (LXBXH): 300 x 150 x 150 mm for partition wall.	4
Metallic Mould	MS fabricated moulds for Solid Concrete Block size (LXBXH): 300 x 100 x 150 mm for partition wall.	4



TARA Eco Concrete – Vibrating table small type.

MS fabricated concrete block metallic mould with bottom plate.

MS fabricated concrete block metallic mould for full and half block.

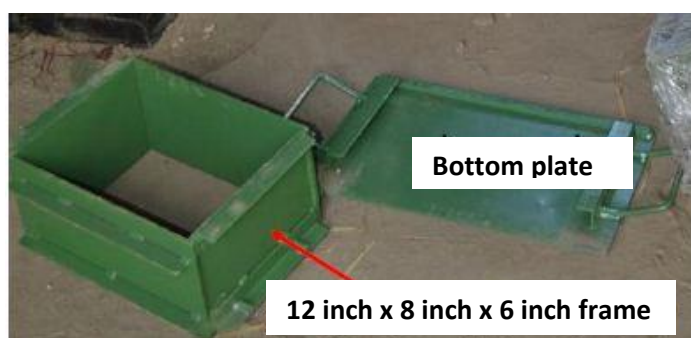

Moulds for solid concrete block block with cavity for vertical reinforcement



Accessories for demoulding of cavity block

Maintenance

	AFTER PRODUCTION	DAILY	WEEKLY	MONTHLY
Casting Moulds	Scrap and clean the mould to remove any concrete left over after the use.	Scrap and clean after use. Do not allow concrete to settle on the mould while not in use.	Through cleaning of corners with brass wire brush.	Coating of surfaces with primer.
Concrete Mixer and Vibrating table	Check free movement of lifting mechanism and transverse movement		Check all electrical contacts. Check and tighten the fastening bolts	Check rpm. Check and clean electrical contacts. Tighten the eccentric. Check bearing and lubrication.

Production unit

The most important component for setting up production unit is the identification of land at appropriate location, which fulfils the production unit space requirements. The location of the production unit must have an easy access to labour, material and transportation facilities. The table below shows the space and other facility requirements for setting up a production unit.

PRODUCTION UNIT SPACE REQUIREMENT	SPECIFICATIONS
Total area of production yard	500 sq.ft (minimum)
Area for machines	20% of total space (approx. 100 sq.ft)
Area for storage of raw materials	40% of total space (approx. 200 sq.ft)
Area for curing and storage of finished products	40% of total space (approx. 200 sq.ft)

INFRASTRUCTURAL REQUIREMENTS
Availability of electricity for minimum 6 hours, for a full production day (3 phased electricity connection for TARA Pan mixer).
Supply of clean water for minimum of 3-4 hours or water storage for curing of blocks.

Efficiency in production depends a great deal on how the site is arranged. A few things must be kept in mind to save valuable time and effort:

- Each day’s output should be in a separately marked areas, with the closest of each area not more than 10m (or 30ft) from the machine.
- To minimize carrying distance take blocks to the construction location directly from these stacks.

Setting up the production unit requires an initial investment – in terms of land, infrastructural cost, cost of machines and equipments and other registration/paperwork charges. Additionally, working capital is needed for raw materials, labour and transportation. The fixed capital is one time investment which is needed for setting up the production unit and working capital is a recurring cost which would be needed as the demand of technology and production requirements.

COMPONENTS	COMPONENTS
Land and infrastructure , includes- production unit land, levelling of land and floor preparation, construction of shed, provision of electricity and water supply line.	*Costing entirely varies as per the market rate of the land and the choice of materials used in the construction of components.
Machinery and equipment, includes – TARA Concrete mixer, vibrating table and metallic moulds.	Approx. 1.5 – 2 Lakhs

Material and Labour requirement for production

The four major raw materials required for concrete block production are - **cement, sand, aggregate (10mm) and aggregate (6mm)**. The quantity of each material is highly dependent on the ratio of the concrete mix – which varies as per the production process and the required compressive strength of the blocks (whether being produced for direct load or just as fillers for wall masonry). The details of concrete mix ratio is provided in the next section.

The material quantity required for production is calculated as per weight of 1 Block and weightage of each raw material required for production of single solid block. Daily production capacity of the production unit is 500 blocks per day by TARA Eco concrete – vibrating table.

Average weight of 1 Solid concrete block – 12 inch x 8 inch x 6 inch	18-20 Kg
Average weight of 1 Hollow concrete block – 12 inch x 8 inch x 6 inch	10-12 Kg

MATERIAL	UNITS	TOTAL QUANTITY FOR 500 SOLID BLOCKS
Cement	Bags (50 kg each)	21
Sand	Bags (40 kg each)	72
Aggregate	Bags (40 kg each)	90
MANPOWER		
Production	Skilled worker days	4 mason
	Unskilled worker days	16 labour

Cement – Portland cement, Grade 43, not older than 3 months.

Sand –

- 30%-40% particles should be of 1/2 to 1 ½ soot (1.58mm to 3.175mm)
- River sand is most appropriate.
- Stone dust or crusher dust can also be used instead of river sand, if large size particles are also mixed in it.

Aggregate –

- Mixed Aggregate of particle size ranging from 6mm to 20 mm
- Should be clean, hard and have a rough surface.

Production Process

Preparation of CB mix

The design of concrete blocks is according to IS 2185 (Part 1): 2005 Indian Standard: Concrete Masonry Units – Specification (Part 1) Hollow and Solid Concrete Blocks (Third Revision). The concept of concrete blocks is based on the utilizing the superior compressive strength of concrete to produce masonry units with strength in accordance with load bearing requirements of masonry. Concrete blocks can be casted in varied sizes – as per the feasibility of weight for easy handling during masonry and suitability to the wall thickness. Usually a person can easily handle 20kg of block, hence the total weight of block should not exceed this weight.

Concrete is prepared with three raw materials- cement, sand and coarse aggregate. The mix design of blocks will vary with the type of end use – load bearing construction, non-load bearing construction or for other uses such as boundary wall.

The main objective of correct proportion of materials is to produce a block of maximum density with the given raw materials. If blocks are to be used for load-bearing construction, then the density of the block should not be less than 1800 kg/m³. The compressive strength of concrete block for load bearing construction upto 2 floors should not be less than 40 kg/cm² (4 N/mm²). A few trial mixes should be tried out at site and sample blocks tested for compressive strength- after this, the mix design can be finalized for production. Blocks for load bearing construction should ideally be produced on a vibrating table and not by manual compaction.

For load bearing construction, indicative mix of concrete is 1 part cement, 1.5-2.5 parts coarse sand and 3-4 parts coarse aggregate. For coarse aggregate, it is best to mix 10-20mm size and below 6mm size to get maximum density of block. If are to be used as filler blocks in RCC frame, then a mix of 1 part cement, 2-3 parts sand and 4-6 parts coarse aggregate can be used.

Stone dust – this is a residual material produced in stone crushing plants and is available in many regions. It is a powdery material with a higher percentage of extremely fine particles as compared to river sand. It can be used in combination with river sand with a 50% replacement. Appropriate measuring of the raw materials is required to prepare good quality mix to attain durable concrete block, for this purpose it is required to weigh the raw material keeping a same container, a Pan or *Tasla*.

Weight of material according to 1 <i>Tasla</i> (pan)	
Weight of empty <i>Tasla</i>	600gm
1 <i>Tasla</i> cement	13kg
1 <i>Tasla</i> sand	20kg
1 <i>Tasla</i> aggregate (20 mm)	19kg
1 <i>Tasla</i> aggregate (6 mm)	21kg



20mm aggregate



6 mm aggregate



Stone Dust



River Sand



Step -1 Mixing

- *In a good concrete, the paste of cement and sand covers all the area uniformly and makes a complete layer over the aggregate.*
- *Mixing of concrete should be preferred in a mixer machine.*
- *If mixing is to be done by hands, then make sure to first mix cement and sand in dry state. Then, add water to this mixture and prepare a smooth paste.*
- *Eventually, add the aggregate and mix it through cutting. If the paste is still slightly dry or hard, add more water to it.*



Step -2 Quantity of water

- *Too much leaner concrete reduces its strength.*
- *Usually, the quantity of water required is half the quantity of cement being used.*
- *Only add that much water which just brings about elasticity in the concrete.*
- *Do not add the entire required water at once.*
- *It is better to add some water while mixing as one can see if the paste is dry and more water needs to be added or not.*

Block production

Step -1 Pouring of Concrete

- It is of utmost importance for the strength of the block to compact the concrete after pouring it into the mould.
- The most appropriate way to compact it properly is by using the 'Vibrating Table'.
- For this, fill the mould in two parts- first fill it halfway and vibrate it for about 4-5 seconds; then immediately pour the other half and level it evenly and again vibrate it for around 6-7 seconds.



- If concrete is to be compacted by hands, pour the concrete into the mould in 3 equal portions and press every portion properly.
- Fill the moulds with the help of a metallic rod



Step -2 Demoulding

- Always remove the mould after the initial setting of concrete.
- Generally, 30 minutes to 1 hour is sufficient for the initial setting.
- In cold weather, it takes more time to set.
- Remove the block by sliding the bottom plate of the mould.
- Remove the mould by placing a piece of plywood ,cut into exact dimensions as that of the block's, and pulling the mould upwards while pushing the block downwards at the same time.



Step -3 Curing

- *Keep the freshly demoulded blocks on level ground/surface in a single layer for a day. Transfer the blocks for stacking in 3-4 layers from the 2nd day onwards. The blocks must be cured with water for a minimum of 14 days before they are used in construction. The stacking and curing should be done in a shaded place and not directly under the sun.*



Construction Process

Masonry with concrete blocks is constructed following the same principles of conventional brick masonry. With hollow blocks, it is also possible to provide vertical reinforcement in the wall. Concrete blocks are good enough for double storey load bearing construction. With blocks of good surface finish and uniform size, it is possible to construct exposed masonry, thus saving on plaster.

Community building constructed under the project '*Delivery Model for Eco-friendly Multi Hazard Resistant Construction Technologies and Habitat Solutions in Mountain States*', demonstrated Concrete block (CB) wall masonry in a double storey building block in Community building at Kamad village, Uttarkashi - with appropriate vertical reinforcement at corner and T-junctions. Along with vertical reinforcement, reinforced concrete bands were also incorporated at sill, lintel and roof level in the masonry for increased seismic resistance and structural stability.



The building has been designed as a load bearing structure with single vertical reinforcements and horizontal RCC bands. The walls have been designed with 3 feet Random Rubble Masonry (RRM) from foundation till sill level and CB masonry in ground and first floor level over RRM. Roof with *Chir pine* timber shingles with timber truss understructure have been installed over concrete block structure and intermediate slab have been constructed with Precast concrete Plank (precast slab modules) and Joist (precast beam modules). CB masonry have been provided with external finishes of lime plaster and paint over RCC bands and internal finishes of half inch cement plaster.



Ground floor masonry and complete double storey masonry with concrete block in community building at kamad village, Uttarkashi.

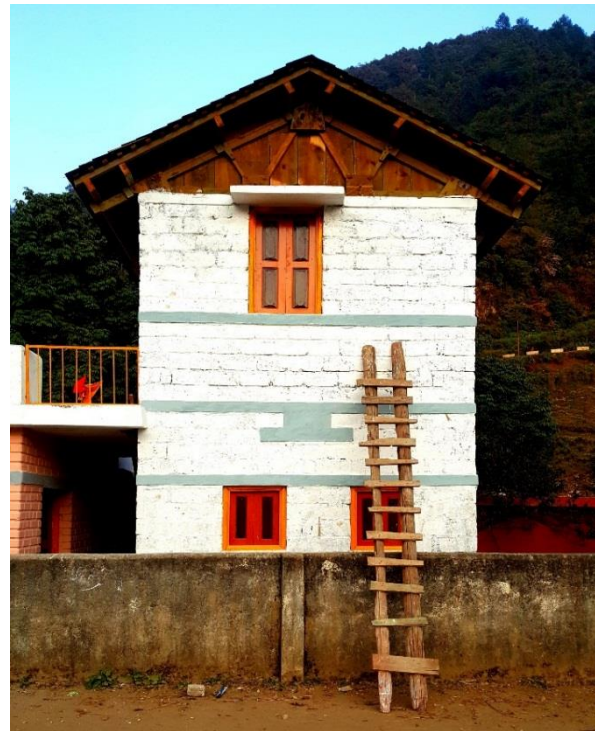

Final structure with external finishes of lime plaster and paint over concrete bands.

The course layout was prepared for concrete block masonry and to identify the types of hollow and solid concrete blocks required for the masonry. Hollow concrete blocks have been designed to accommodate single vertical reinforcements at the corner, T-junctions and at sides of door and windows. CB were used in 8 inch thick external walls of Kitchen, store and guest rooms (at ground and first floor level) and 4 inch thick internal partition wall. Two different types of solid concrete blocks and four types of hollow concrete blocks have been used in the building. Below are the details of types of concrete blocks used and their application in course layout.

Type 1 - Solid Concrete Block	12 inch x 8 inch x 6 inch	Used in the external 8 inch thick wall.
Type 2 - Solid Concrete Block	12 inch x 4 inch x 6 inch	Used in the internal 4 inch thick partition wall.
Type 3 – Hollow Concrete Block (with cavity at the center of 12 inch edge)	12 inch x 8 inch x 6 inch	Used in T- junctions
Type 4 – Hollow Concrete Block (with cavity at 8 inch edge)	12 inch x 8 inch x 6 inch	Used in T- junctions and corner junctions
Type 5 – Hollow Concrete Half Block (with cavity at 8 inch edge)	6 inch x 8 inch x 6 inch	Used in sides of doors and windows.
Type 6– Hollow Concrete Half Block (with cavity at 6 inch edge)	6 inch x 8 inch x 6 inch	

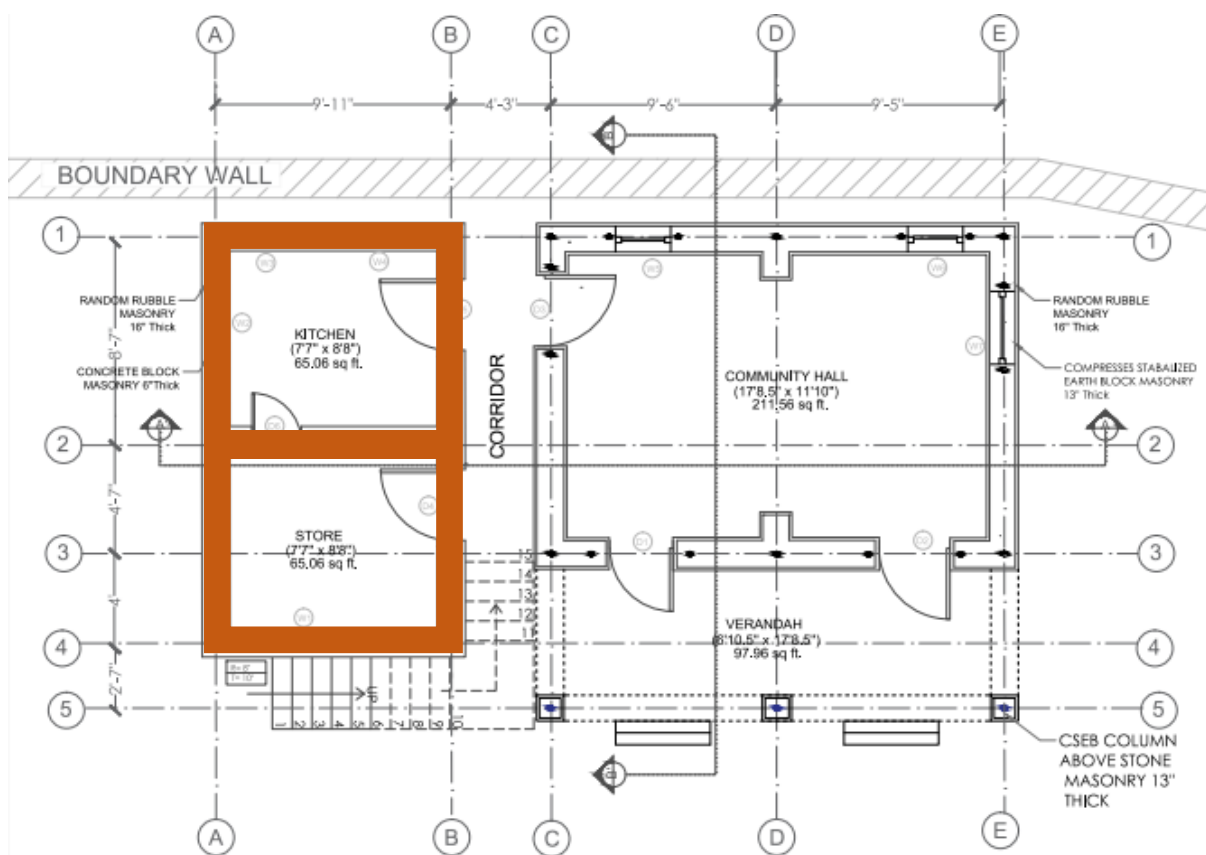

 Concrete block masonry with 8 inch wall thickness in double storey block – Kitchen and store at ground level and rooms at first floor level.



Type 1 and Type 2 Solid concrete blocks – 12 inch x 8 inch x 6 inch for external wall and 12 inch x 4 inch x 6 inch for internal partition wall.



Type 3 and Type 6 of hollow concrete half blocks-at left side 12 inch x 8 inch x 6 inch with cavity at 12 inch side for T-junctions and right side 6 inch x 8 inch x 6 inch half block with cavity at 6 inch edge.



Type 4 -Hollow concrete block of size – 12 inch x 8 inch x 6 inch for corner junctions.



Type 5 -Hollow concrete half block of size – 6 inch x 8 inch x 6 inch with cavity at 8 inch edge.



Overlapping of hollow concrete blocks.

Below are the types of concrete blocks along with their masonry details –

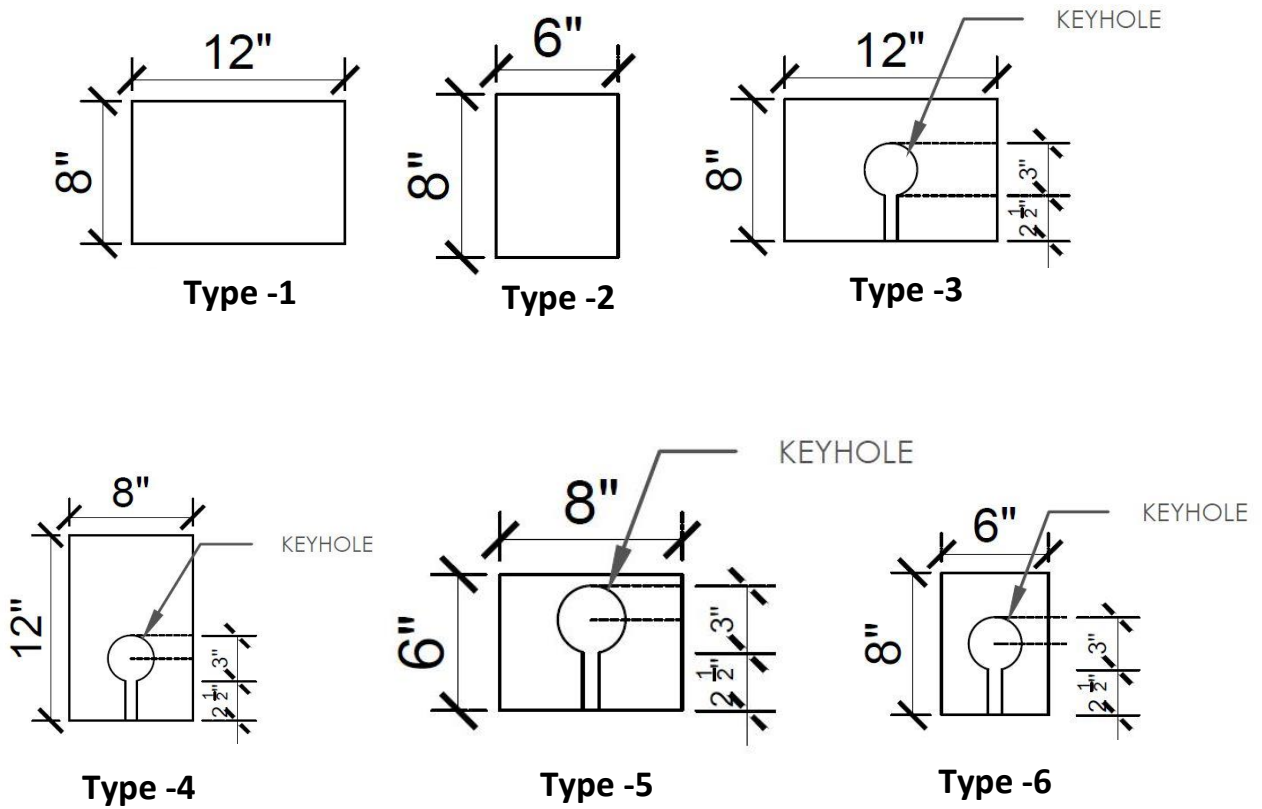

CORNER JUNCTION

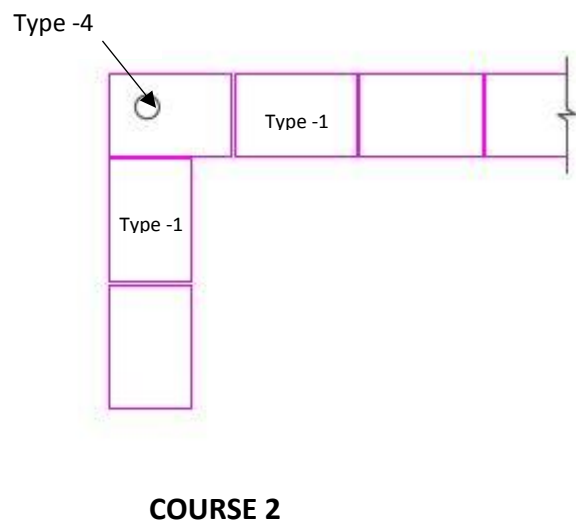
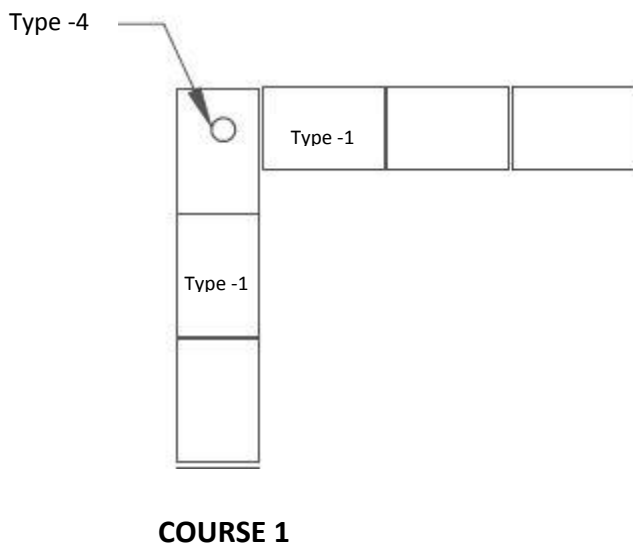

T-JUNCTION

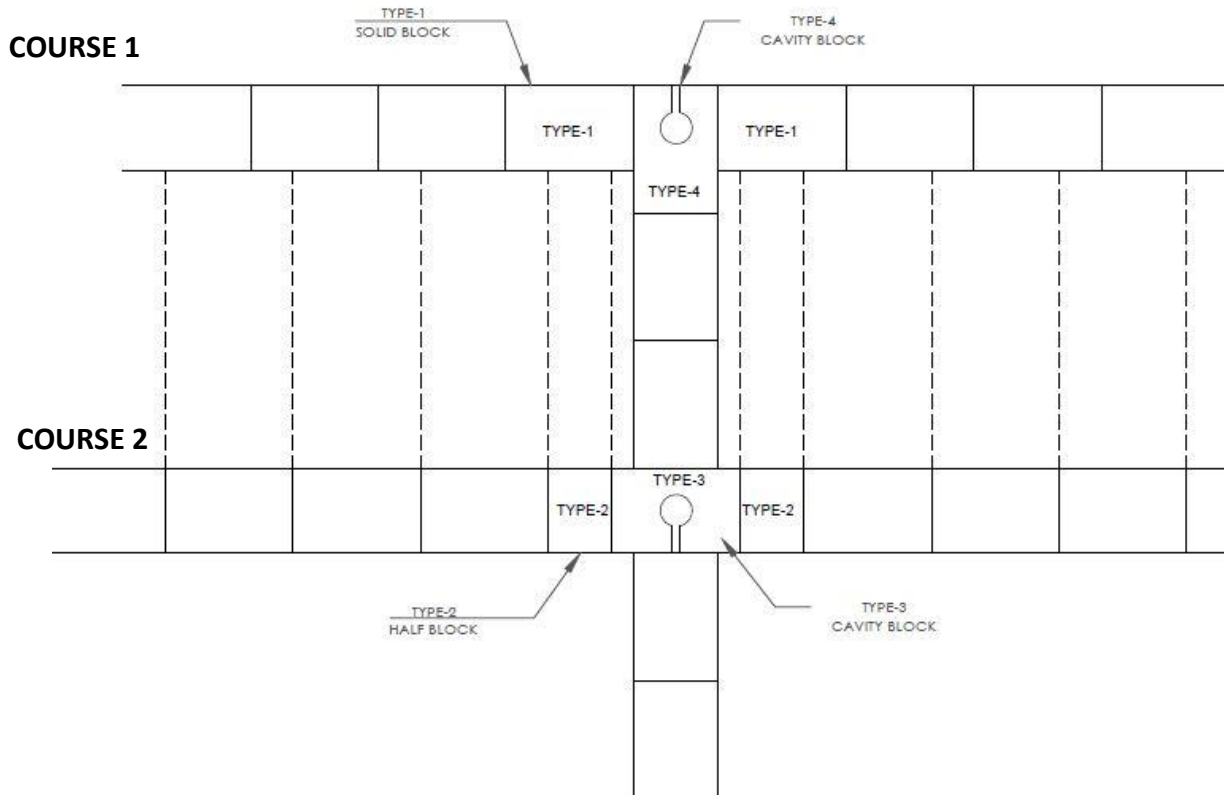

WINDOW JUNCTION

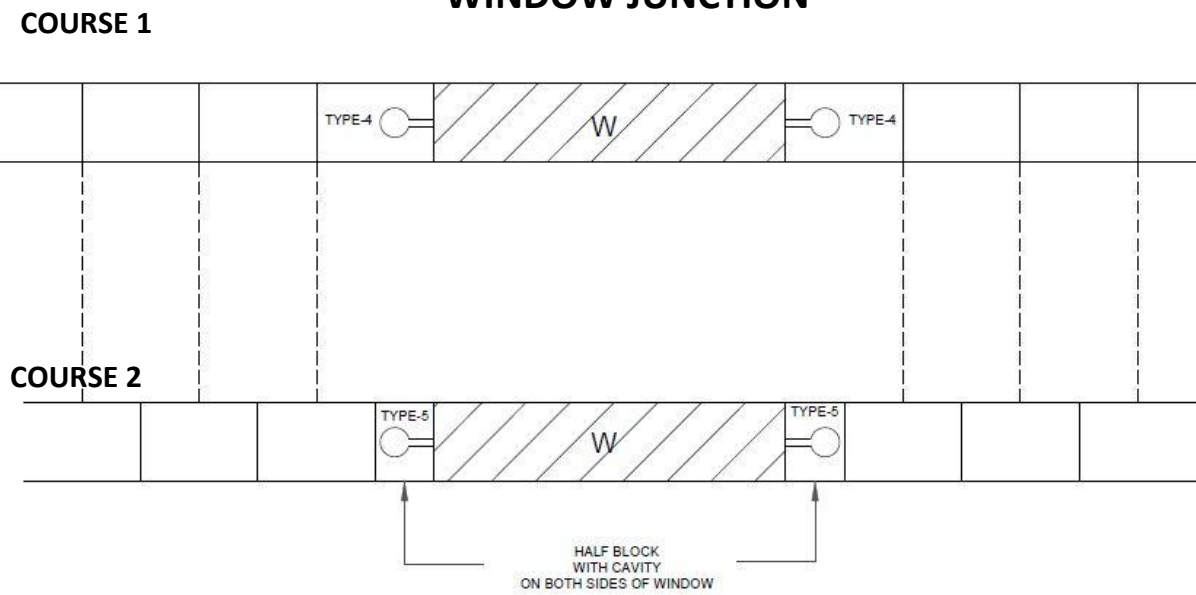



Double storey concrete block structure in community building at Kamad village, Uttarkashi.



Double storey concrete block structure in community building at Kamad village, Uttarkashi after external finishes with lime plaster and paint. Lintel band casting over concrete block masonry.

Communication Material

Technology Production Poster – A3 size

कंक्रीट ब्लॉक

कंक्रीट ब्लॉक दीवार की चिनाई करने के लिए एक वैकल्पिक सामग्री है। इस ब्लॉक को साधारण कंक्रीट के एक सांचे में ढाल कर बनाया जाता है। यह ब्लॉक साधारण पकी हुई ईंट से 4.5–8 गुणा बड़े साइज का होता है।



कंक्रीट ब्लॉक का साइज सांचे के आधार पर निर्भर होता है।

कंक्रीट ब्लॉक के सामान्य साइज

लंबाई – 16", 12", 8"

चौड़ाई – 3", 4", 6", 8"– यह दीवार की मोटाई के बराबर है

ऊंचाई– 5", 6", 8"

कंक्रीट ब्लॉक बनाने का मूल सिद्धांत

कंक्रीट ब्लॉक बनाने का मिश्रण आम बीम या छत में डले कंक्रीट से अलग होता है। मिश्रण इस आधार पर तैयार किया जाना चाहिए जिससे ब्लॉक में सीमेंट की मात्रा सिर्फ उतनी ही हो जिससे ब्लॉक में दीवार बनाने लायक मजबूती आ सके।

12" x 8" x 6" ब्लॉक का साइज					
सीमेंट	बजरी	गिट्टी	एक सीमेंट कट्टे में कितने ब्लॉक?	प्रति ब्लॉक कितना सीमेंट?	मिश्रण में सीमेंट का अनुपात
1	3	6	24	2 किलो	प्रति ब्लॉक में इस से ज्यादा सीमेंट की आवश्यकता नहीं है
1	5	8	34	1.5 किलो	प्रति ब्लॉक में इस से कम सीमेंट की मात्रा नहीं होनी चाहिए



हेस्को
देहरादून



डेवलपमेंट ऑल्टरनेटिव्स
नई दिल्ली



Government of India
Department of Science & Technology
Ministry of Science & Technology

कंक्रीट ब्लॉक बनाने की प्रक्रिया

1. अच्छी सामग्री का चुनाव

सीमेंट – ओ पी सी 43 ग्रेड सीमेंट, तीन महीने से ज्यादा पुराना नहीं

बालू – मोटे दाने वाली और साफ बालू—जिसमें आधे से डेढ़ सूत साइज के कण 30–40% हो। नदी की बालू सबसे उचित है।

गिट्टी – 2 से 6 सूत साइज की मिली-जुली गिट्टी। गिट्टी साफ, सख्त पत्थर की और खुरदरे सतह की होनी चाहिए।



बालू



स्टोन इस्ट



गिट्टी

2. सही अनुपात से मिश्रण

सीमेंट, बालू, गिट्टी को सही अनुपात में तोल कर मिलाना टिकाऊ कंक्रीट के लिए अत्यंत आवश्यक है। यह सुनिश्चित करें कि नाप-तोल की वस्तु में कितने वजन की सामग्री समाती है।

एक तसले के आधार पर सामग्री का वजन
(600 ग्राम खाली तसला का वजन)

एक तसला सीमेंट = 13 किलो

एक तसला क्रशर डस्ट = 20 किलो

एक तसला 3 – 6 सूत साइज गिट्टी = 19 किलो

एक तसला 2 सूत साइज गिट्टी = 21 किलो



एक सीमेंट के कट्टे में 2.5 से 3 तसला सामग्री नापी जा सकती है

कमद में बनाये जा रहे कंक्रीट ब्लॉक में सामग्री का अनुपात

	सीमेंट	बालू	गिट्टी
बिना वाइब्रेटर मशीन के बने ब्लॉक	1 भाग	3 भाग	6 भाग
वाइब्रेटर मशीन के बने ब्लॉक	1 भाग	4 भाग	7 भाग



हेस्को
देहरादून



डेवलपमेंट ऑल्टरनेटिव्स
नई दिल्ली



Government of India
Department of Science & Technology
Ministry of Science & Technology

3. कंक्रीट तैयार करना

अच्छे कंक्रीट में सीमेंट और बालू का गारा हर जगह एक समान पहुंच कर गिट्टी पर एक परत बना लेता है।

कोशिश रहे कि कंक्रीट की मिलावट मिक्सर मशीन से की जाये।

यदि हाथ से मिलावट करनी हो तो पहले सीमेंट और बालू को सूखा मिलायें। फिर इस मिश्रण में पानी डालें और एक मुलायम गारा तैयार करें। अंत में गिट्टी को डालें और फिर से पूरी मिलावट काट-काट कर करें। इस दौरान यदि मिश्रण रूखा या सख्त हो तो थोड़ा और पानी डालें।



पानी की मात्रा

जरूरत से ज्यादा ढीला कंक्रीट उसकी मजबूती को कम करता है।

1. आम तौर पर जितना सीमेंट हो, उसकी आधी मात्रा का पानी पर्याप्त होता है। सिर्फ उतना ही पानी डालें जिससे कंक्रीट में जरा सा लचीलापन आये।



मग 1 लीटर

2. पूरा पानी एक साथ ना डालें। कुछ पानी मिलावट के दौरान डालना ठीक होता है, जब आप देख सकते हैं कि मिश्रण में सूखापन है या नहीं।

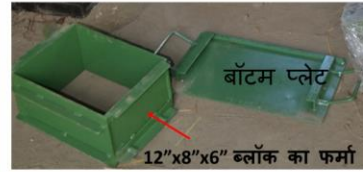

4. ब्लॉक बनाने का फर्मा

ब्लॉक बनाने के लिए स्टील का फर्मा सबसे बेहतर है।

छेद वाले ब्लॉक— इस तरह ब्लॉक में छेद छोड़ा जा सकता है। यह भूकंप के दृष्टिकोण से विशेष रूप से जरूरी है जिससे चिनाई में खड़ा सरिया रखा जायेगा।



छेद वाला आधा ब्लॉक



हेस्को
देहरादून



डेवलपमेंट ऑल्टरनेटिव्स
नई दिल्ली



Government of India
Department of Science & Technology
Ministry of Science & Technology

5. कंक्रीट भरना

कंक्रीट भरने के साथ-साथ उसे सुगठित (कॉम्पैक्ट) करना भी ब्लॉक की मजबूती के लिये अत्यंत आवश्यक है।

इसका सबसे उचित तरीका है विब्रेटिंग टेबल। इसके लिये फर्मा को दो भाग में भरें— आधा भरने के बाद 4–5 सेकंड तक वाइब्रेट करें और फिर तुरंत पूरा भर कर 6–7 सेकंड के लिये वाइब्रेट करें।

यदि हाथ से कंक्रीट को कॉम्पैक्ट करना हो तो कंक्रीट को 3 भाग में भरें और हर भाग को अच्छे से दबायें। एक लोहे की छड़ से कंक्रीट के खाचों को अच्छे से भरें।



6. फर्मा खोलना

कंक्रीट की शुरुआती सेटिंग होने के बाद ही फर्मा खोलें।

आम तौर पर इसके लिये 30 मिनट से एक घंटा पर्याप्त होता है। ज्यादा ठंडे मौसम में शुरुआती सेटिंग को ज्यादा समय लगता है।



ब्लॉक के फर्मा को बॉटम प्लेट से सिरका कर बाहर निकालें

एक ब्लॉक के आकार में कटे प्लाई या लकड़ी से ब्लॉक पर दबाव डाल कर फर्मे को ऊपर की ओर सिरका कर खोलें।

7. तराई

ब्लॉक बनाने के एक दिन बाद से उसकी 14 दिन तक तराई करें। इसके लिए ब्लॉक के चट्टे को एक सोखते कपड़े से ढकें और उसे गीला बनाये रखें।



हेस्को
देहरादून



डेवलपमेंट ऑल्टरनेटिव्स
नई दिल्ली



Government of India
Department of Science & Technology
Ministry of Science & Technology

Technology Production Poster – A2 size

कंक्रीट ब्लॉक

कंक्रीट ब्लॉक

कंक्रीट ब्लॉक दीवार की चिनाई करने के लिए एक वैकल्पिक सामग्री है। इस ब्लॉक को साधारण कंक्रीट के एक सांचे में ढाल कर बनाया जाता है। यह ब्लॉक साधारण पकी हुई ईंट से 4.5-8 गुणा बड़े साइज का होता है।



कंक्रीट ब्लॉक का साइज सांचे के आधार पर निर्भर होता है।
कंक्रीट ब्लॉक के सामान्य साइज लंबाई – 16", 12", 8" चौड़ाई – 3", 4", 6", 8" – यह दीवार की मोटाई के बराबर है ऊंचाई – 5", 6", 8"

कंक्रीट ब्लॉक बनाने का मूल सिद्धांत

कंक्रीट ब्लॉक बनाने का मिश्रण आम शीम या छत में डले कंक्रीट से अलग होता है। मिश्रण इस आधार पर तैयार किया जाना चाहिए जिससे ब्लॉक में सीमेंट की मात्रा सिर्फ उतनी ही हो जिससे ब्लॉक में दीवार बनाने लायक मजबूती आ सके।

12" x 8" x 6" ब्लॉक का साइज					
सीमेंट	बजरी	गिट्टी	एक सीमेंट कट्टे में प्रति ब्लॉक कितने ब्लॉक?	मिश्रण में सीमेंट का अनुपात	प्रति ब्लॉक में इस से ज्यादा सीमेंट की आवश्यकता नहीं है
1	3	6	24	2 किलो	प्रति ब्लॉक में इस से कम सीमेंट की मात्रा नहीं होनी चाहिए
1	5	8	34	1.5 किलो	

कंक्रीट ब्लॉक बनाने की प्रक्रिया

1. अच्छी सामग्री का चुनाव

सीमेंट – ओ पी सी 43 ग्रेड सीमेंट, तीन महीने से ज्यादा पुराना नहीं
बालू – मोटे दाने वाली और साफ बालू-जिसमें आधे से डेढ़ सूत साइज के कण 30-40% हो। नदी की बालू सबसे उचित है।
गिट्टी – 2 से 6 सूत साइज की मिली-जुली गिट्टी। गिट्टी साफ, सख्त पत्थर की और खुरदरे सतह की होनी चाहिए।



2. सही अनुपात से मिश्रण

सीमेंट, बालू, गिट्टी को सही अनुपात में तोल कर मिलाना टिकाऊ कंक्रीट के लिए अत्यंत आवश्यक है। यह सुनिश्चित करें कि नाप-तोल को वस्तु में किलने वजन की सामग्री समाती है।

एक तसले के आधार पर सामग्री का वजन (600 ग्राम खाली तसला का वजन)

एक तसला सीमेंट = 13 किलो
एक तसला क्रशर डस्ट = 20 किलो
एक तसला 3 – 6 सूत साइज गिट्टी = 19 किलो
एक तसला 2 सूत साइज गिट्टी = 21 किलो



एक सीमेंट के कट्टे में 2.5 से 3 तसला सामग्री नापी जा सकती है।

कमद में बनाये जा रहे कंक्रीट ब्लॉक में सामग्री का अनुपात

	सीमेंट	बालू	गिट्टी
बिना वाइब्रेटर मशीन के बने ब्लॉक	1 भाग	3 भाग	6 भाग
वाइब्रेटर मशीन के बने ब्लॉक	1 भाग	4 भाग	7 भाग

3. कंक्रीट तैयार करना

अच्छे कंक्रीट में सीमेंट और बालू का मारा हर जगह एक समान पहुंच कर गिट्टी पर एक परत बना लेता है।

कोशिश रहे कि कंक्रीट की मिलावट मिक्सर मशीन से की जाये।

यदि हाथ से मिलावट करनी हो तो पहले सीमेंट और बालू को सूखा मिलाये। फिर इस मिश्रण में पानी डालें और एक मुलायम मारा तैयार करें। अंत में गिट्टी को डालें और फिर से पूरी मिलावट काट-काट कर करें। इस दौरान यदि मिश्रण रूखा या सख्त हो तो थोड़ा और पानी डालें।



पानी की मात्रा

जरूरत से ज्यादा ढीला कंक्रीट उसकी मजबूती को कम करता है।

1. आम तौर पर जितना सीमेंट हो, उसकी आधी मात्रा का पानी पर्याप्त होता है। सिर्फ उतना ही पानी डालें जिससे कंक्रीट में जरा सा लचीलापन आये।

2. पूरा पानी एक साथ ना डालें। कुछ पानी मिलावट के दौरान डालना ठीक होता है, जब आप देख सकते हैं कि मिश्रण में सूखापन है या नहीं।



4. ब्लॉक बनाने का फर्मा

ब्लॉक बनाने के लिए स्टील का फर्मा सबसे बेहतर है। छेद वाले ब्लॉक- इस तरह ब्लॉक में छेद छोड़ा जा सकता है। यह भूकंप के दृष्टिकोण से विशेष रूप से जरूरी है जिससे चिनाई में खड़ा सरिया रखा जायेगा।



5. कंक्रीट भरना

कंक्रीट भरने के साथ-साथ उसे सुगठित (कॉम्पैक्ट) करना भी ब्लॉक की मजबूती के लिये अत्यंत आवश्यक है।

इसका सबसे उचित तरीका है विब्रेटिंग टेबल। इसके लिये फर्मा को दो भाग में भरे- आधा भरने के बाद 4-5 सेकंड तक वाइब्रेट करें और फिर तुरंत पूरा भर कर 6-7 सेकंड के लिये वाइब्रेट करें।

यदि हाथ से कंक्रीट को कॉम्पैक्ट करना हो तो कंक्रीट को 3 भाग में भरे और हर भाग को अच्छे से दबायें। एक लोहे की छड़ से कंक्रीट के खांचों को अच्छे से भरे।



6. फर्मा खोलना

कंक्रीट की शुरूआती सेटिंग होने के बाद ही फर्मा खोलें।

आम तौर पर इसके लिये 30 मिनट से एक घंटा पर्याप्त होता है। ज्यादा ठंडे मौसम में शुरूआती सेटिंग को ज्यादा समय लगता है।



ब्लॉक के फर्मा को एक ब्लॉक के आकार में कटे प्लाई या लकड़ी से ब्लॉक पर दबाव डाल कर बॉटम प्लेट से सिरका फर्मे को ऊपर की ओर सिरका कर खोलें।

7. तराई

ब्लॉक बनाने के एक दिन बाद से उसकी 14 दिन तक तराई करें। इसके लिए ब्लॉक के घट्टे को एक सोखते कपड़े से ढकें और उसे गीला बनाये रखें।





About Development Alternatives Group

Development Alternatives (DA) is a premier social enterprise with a global presence in the fields of green economic development, social equity and environmental management. It is credited with numerous technology and delivery system innovations that help create sustainable livelihoods in the developing world. DA focuses on empowering communities through strengthening people's institutions and facilitating their access to basic needs; enabling economic opportunities through skill development for green jobs and enterprise creation; and promoting low carbon pathways for development through natural resource management models and clean technology solutions.

Development Alternatives

B-32, Tara Crescent, Qutub Institutional Area
New Delhi 110016, India

Tel: +91-11-2654-4100, 2654-4200, Fax: +91-11-2685-1158
Email: mail@devalt.org, Website: www.devalt.org